

# QE-3.3 LIFT OFF ENCLOSURE SPECIFICATIONS

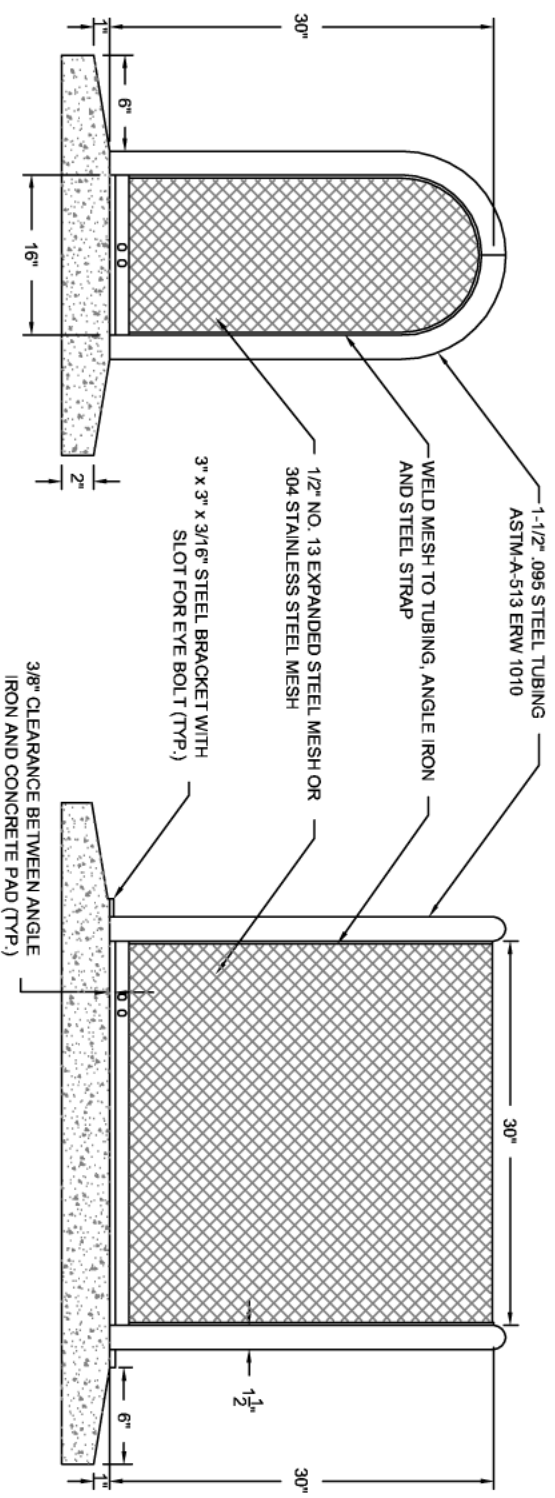

**NOTES:**

1. ALL WELDS MIN. 1/4" BEAD EVERY 4" O.C.
2. IRON PHOSPHATE PRETREATMENT PRIOR TO PAINT
3. PAINT TO BE ELECTROSTATIC POWDER COAT-  
RAL 1019 TAN, FOREST GREEN OR APPROVED EQUAL

**INSIDE DIMENSIONS**

MODEL	WIDTH	HEIGHT	LENGTH	WEIGHT
QE-.5	10"	18"	12"	24 lbs
QE-1	10"	24"	22"	35 lbs
QE-2	10"	24"	30"	42 lbs
QE-3	10"	24"	40"	47 lbs
QE-3.3	16"	30"	30"	N/A
QE-4	16"	30"	46"	N/A

**QUALITY ENCLOSURE** <sup>TM</sup>

PH 602-277-3698 FAX 1-888-872-4223  
QualityEnclosureOnline.com

SCALE: 1"=1' DATE: 6/16/09  
DETAIL:

**QE-3.3**



REV